



ALPEREN
ENDÜSTRİ VE TİCARET



Ürün Kataloğu
Product Catalogue



ALPEREN
ENDÜSTRİ VE TİCARET

Acidereosb mah. Çiğdem sk. No: 4/1 Sarıçam/ADANA

MAIL : info@alperentr.com

WEB : www.alperentr.com

TEL: 0532 659 0168



FİRMA PROFİLİ

Yıllar önce atılmış temeller üzerine kaliteden ödün vermeden inşaa ettiğimiz pazarlama tecrübemiz ve imalat yeteneklerimiz ile her geçen gün artan kapasitemizle, hiç durmadan bilgi birikimimizi arttırıyor ve eşsiz değerlerimizi çalışanlarımızla, geleceğin ustalarıyla, işçilerimizle ve iş insanlarıyla paylaşıyoruz.

Alperen Altyapı Malzemeleri Endüstriyel Ltd.Şti. Flanş üretim faaliyetlerine 2025 yılında sanayicilerin güvenle yatırım yaptığı, üretimin ve istihdamın kesintisiz desteklendiği bir sanayi üssü olan Adana Organize Sanayi Bölgesinde başlamıştır. Firmamız çalışmalarını 3.500 m2 arazi üzerinde 2.800 m2 lik kapalı alanda Flanş Üretim tesisi ve idari ofisleriyle sürdürmektedir.

Firmamızın üretim tesisinde TSE, Avrupa ve Amerikan normlarına göre imalat standartlarını belirlemiş olan firmamız, Türkiye piyasasının endüstriyel ürün ihtiyaçlarını karşılayan bir üretici konumundadır.

Endüstriyel, Kimyasal ve tarımsal ürünlerin bağlantı parçaları üretimi ağırlıklı devam eden tesisimizin kapasitesi yılda 6.000 ton flanş üretimine sahiptir. Firmamızın modern tesislerinde 25mm – 1000mm ölçülerinde PN6 'dan PN40 'a kadar DÜZ FLANŞ, KÖR FLANŞ, PE FLANŞ, BUHAR (BORULU) FLANŞI, DÖNER FLANŞ ve SLİP ON FLANŞ üretmektedir.

Firmamız İnşaat, Isıtma, Soğutma, Havalandırma, Enerji, Sulama, Arıtma, Petro Kimya Tesisleri, Mekanik Tesisat, Gemi Endüstrisi ve Maden İşletme sektörlerinin Flanş İhtiyaçlarını % 100 yerli üretim ile karşılamaktadır.

Alperen Ailesi olarak çalışma hevesi ve yüksek azimle ülkemizin dört bir yanında, dışa bağımlılığı azaltmak ve yerli sanayinin gelişimini desteklemek ile birlikte ALPFLANŞ markamız ile de Dünya'da 60'tan fazla ülkeye ihracat yaparak ülke ekonomisine katkıda bulunacağız. 2025 Yılında ALPFLANŞ markası ile ENDÜSTRİYEL alandaki yeni girişimimiz ile birlikte hedeflerimiz doğrultusunda istihdam sayımızı artırarak başta ülkemiz olmak üzere global pazarda üretime hiç ara vermeden devam edeceğiz."

COMPANY PROFILE

Built upon foundations laid years ago, and with our marketing experience and manufacturing capabilities built without compromising on quality, and with our ever-increasing capacity, we continuously enhance our knowledge and share extraordinary values with our employees, future masters, workers, and business people.

Alperen Infrastructure Materials Industrial Ltd. Co. started its flange production activities in 2025 in the Adana Organized Industrial Zone, an industrial hub where industrialists invest and production and employment are continuously supported. Our company's laboratory occupies 2,800 m2 of enclosed space on a 3,500 m2 plot of land, housing flange production technology and administrative offices.

Our company's production model is based on TSE, European, and American norms, establishing manufacturing standards and positioning us as a manufacturer meeting the industrial product specifications of the Turkish market.

Our facility, primarily focused on the production of controllable connection parts for industrial, chemical, and solution applications, has an annual compression production capacity of 6,000 tons. Our company manufactures FLAT FLANGES, BLIND FLANGES, PE FLANGES, STEAM (PIPE) FLANGES, ROTARY FLANGES, and SLIP-ON FLANGES in sizes from 25mm to 1000mm, from PN6 to PN40, in our modern facilities.

Our company can meet the flange needs of the Construction, Heating, Cooling, Ventilation, Energy, Irrigation, Wastewater Treatment, Petrochemical Plants, Mechanical Installations, Shipbuilding Industry, and Mining sectors with 100% domestic production.

As the Alperen Family, with our enthusiasm and high determination, we will contribute to the national economy by supporting the development of domestic industry and expanding our reach to over 60 countries worldwide with our ALPFLANŞ brand. In 2025, with our new venture in the INDUSTRIAL sector under the ALPFLANŞ brand, our goals are to increase our employment numbers and continue production without interruption, primarily in the global market.

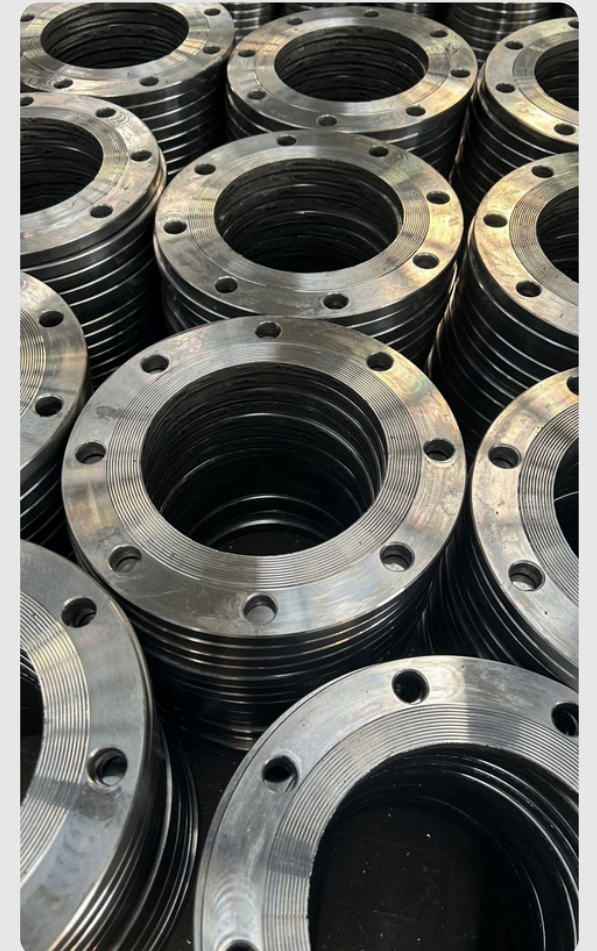



► DÜZ GEÇME FLANŞ / SLIP-ON FLANGE

- ASA 300 LB
- ANSI B 16.5
- TS EN 1759-1

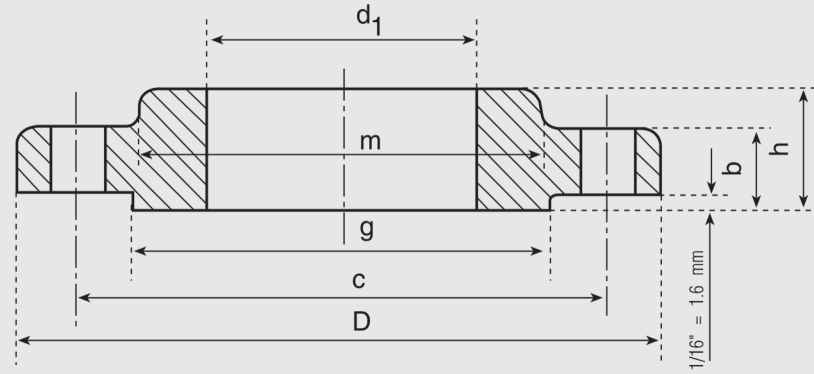

BORU / PIPE		D	b	c	Delik Hole	Vida Screw	h	m	g	Ağırlık Weight									
Dış Çap O.D.	d ₁									Pcs	Pounds	kg							
DN	mm	Inch	mm	Inch	mm	Inch	mm	Inch	mm	Pounds	kg								
1/2	0,88	22,3	3 3/4	95,2	9/16	14,3	2 5/8	66,7	4	5/8	15,9	7/8	22,2	1 1/2	38,1	1 3/8	34,9	2	0,9
3/4	1,09	27,7	4 5/8	117,5	5/8	15,9	3 1/4	82,5	4	3/4	19	1	25,4	1 7/8	47,6	1 11/16	42,9	3	1,3
1	1,36	34,5	4 7/8	123,6	11/16	17,5	3 1/2	88,9	4	3/4	19	11/16	27	2 1/8	54	2	50,8	3	1,4
1 1/4	1,70	43,2	5 1/4	133,3	3/4	19	3 7/8	98,4	4	3/4	19	11/16	27	2 1/2	63,5	2 1/2	63,5	4	1,8
1 1/2	1,95	49,5	6 1/8	155,6	13/16	20,6	4 1/2	114,3	4	7/8	22,2	13/16	30,2	2 3/4	69,8	2 7/8	73	6	2,5
2	2,44	62	6 1/2	165,1	7/8	22,2	5	127	8	3/4	19	15/16	33,3	3 5/16	84,1	3 5/8	92,1	7	3
2 1/2	2,94	74,7	7 1/2	190,5	1	25,4	5 7/8	149,7	8	7/8	22,2	1 1/2	38,1	3 15/16	100	4 1/8	104,8	10	4,5
3	3,57	90,7	8 1/7	290,5	1 1/8	28,6	6 5/8	168,3	8	7/8	22,2	1 11/16	42,9	4 5/8	117,5	5	127	13	6
3 1/2	4,07	103,4	9	228,5	1 3/16	30,2	7 1/4	184,1	8	7/8	22,2	1 3/4	44,4	5 1/4	133,3	5 1/2	139,7	17	7,7
4	4,57	116,1	10	254	1 1/4	31,8	7 7/8	200	8	7/8	22,2	1 7/8	47,6	5 3/4	146	6 3/16	157,2	22	10
5	5,66	143,8	11	279,4	1 3/8	34,9	9 1/4	234,9	8	7/8	22,2	2	50,8	7	177,8	7 5/16	185,7	28	12,5
6	6,72	170,7	12 1/2	317,5	1 7/16	36,5	10 5/8	269,9	12	7/8	22,2	2 1/16	52,4	8 1/8	206,4	8 1/2	215,9	39	17,5
8	8,72	221,5	15	381	1 5/8	41,3	13	330,2	12	1	25,4	27/16	61,9	10 1/4	260,3	10 5/8	269,9	58	26
10	10,88	276,3	17 1/2	444,5	1 7/8	47,6	15 1/4	387,3	16	1 1/8	28,6	2 5/8	66,7	12 5/8	320,7	12 3/4	323,8	81	36,5
12	12,88	327,1	20 1/2	520,7	2	50,8	17 3/4	450,8	16	1 1/4	31,7	2 7/8	73	14 3/4	374,6	15	381	115	52
14	14,14	359,2	23	584,2	2 1/8	54	20 1/4	514,3	20	1 1/4	31,7	3	76,2	16 3/4	425,4	16 1/4	412,7	165	75
16	16,16	410,4	25 1/2	647,7	1 1/4	57,2	22 1/2	571,5	20	1 3/8	34,9	3 1/4	82,5	19	482,6	18 1/2	469,9	190	86
18	18,18	461,8	28	711,2	2 3/8	60,3	24 3/4	628,5	24	1 3/8	34,9	3 1/2	88,9	21	533,4	21	533,4	250	113
20	20,20	513,1	30 1/2	774,7	2 1/2	63,5	27	685,8	24	1 3/8	34,9	3 3/4	95,2	23 1/8	587,4	23	584,2	315	143
24	24,25	616	36	914,4	2 3/4	69,8	32	812,8	24	1 5/8	41,3	4 3/16	106,4	27 5/8	701,7	27 1/4	692,1	475	215
26	26,25	666,75	38 1/4	971,5	3 1/8	79,4	34 1/2	876,3	28	1 3/4	44,4	7 1/4	184,15	28 3/8	720,7	29 1/4	749,3	570	259
28	28,25	717,55	40 3/4	1035	3 3/8	85,7	37	939,8	28	1 3/4	44,4	7 3/4	196,85	30 1/2	774,7	31 1/2	800,1	720	327
30	30,25	768,35	43	1092,2	3 5/8	92,1	39 1/4	996,9	28	1 7/8	47,6	8 1/4	209,55	32 9/16	827,1	33 3/4	857,2	810	368
32	32,25	819,15	45 1/4	1149,3	3 7/8	98,4	41 1/2	1054,1	28	2	50,8	8 3/4	222	34 11/16	881,05	36	914,4	890	404
34	34,25	869,95	47 1/2	1206,5	4	101,6	43 1/2	1104,9	28	2	50,8	9/18	231,8	36 7/8	936,6	38	965,2	1075	488
36	36,25	920,75	50	1270	4 1/8	104,8	46	1168,4	32	2 1/8	54	9 1/2	241,3	39	990,6	40 1/4	1022,3	1200	545



ALPEREN DİKİŞSİZ ÇELİK ÇEKME BORU
ALPEREN SEAMLESS STEEL PIPES



► **KAYNAK BOYUNLU FLANŞ /
WELDING NECK FLANGE**

- Anma Basıncı / PN:40 kgf/cm²
- DIN 2635
- EN 1092-1 TİP II

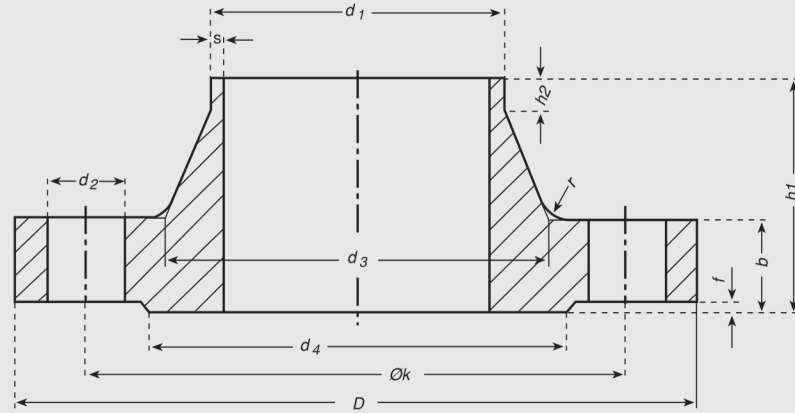

BORU / PIPE		FLANŞ / FLANGE				BOYUN NECK				ALIN ÇIKINTISI RAISED FACE		CIVATALAR BOLTS			Ağırlık Weight (7,85 kg / dm ³) kg.
d	d ₁	D	b	k	h ₁	d ₃	s	r	h ₂	d ₄	f	Delik Hole	Vida Screw	d ₂	
10	14	90	16	60	35	25	1,8	4	6	40	2	4	M 12	14	0,661
	17,2					28									
15	20	95	16	65	38	30	2	4	6	45	2	4	M 12	14	0,746
	21,3					32									
20	25	105	18	75	40	38	2,3	4	6	58	2	4	M 12	14	1,06
	26,9					40									
25	30	115	18	85	40	42	2,6	4	6	68	2	4	M 12	14	1,29
	33,7					46									
32	38	140	18	100	42	52	2,6	6	6	78	2	4	M 16	18	1,88
	42,4					56									
40	44,5	150	18	110	45	60	2,6	6	7	88	3	4	M 16	18	2,33
	48,3					64									
50	57	165	20	125	48	72	2,9	6	8	102	3	4	M 16	18	2,82
	60,3					75									
65	76,1	185	22	145	52	90	2,9	6	10	122	3	8	M 16	18	3,74
	88,9					105									
80	88,9	200	24	160	58	105	3,2	8	12	138	3	8	M 16	18	4,75
	108					128									
100	114,3	235	24	190	65	134	3,6	8	12	162	3	8	M 20	22	6,52
	133					155									
125	139,7	270	26	220	68	162	4	8	12	188	3	8	M 24	26	9,07
	159					182									
150	168,3	300	28	250	75	192	4,5	10	12	218	3	8	M 24	26	11,8
	191					215									
175	193,7	350	30	295	80	218	5,6	10	15	260	3	12	M 27	30	18,2
	216					240									
200	219,1	375	34	320	88	244	6,3	10	16	285	3	12	M 27	30	21,5
	267					298									
250	273	450	38	385	105	306	7,1	12	18	345	3	12	M 30	33	34,9
	318					352									
300	323,9	515	42	450	115	362	8	12	18	410	4	16	M 30	33	49,7
	355,6					408									
350	368	580	46	510	125	408	8,8	12	20	465	4	16	M 33	36	68,1
	406,4					462									
400	419	660	50	585	135	462	11	12	20	535	4	16	M 36	39	96,5
	508					562									
500	521	755	57	670	140	562	14,2	12	20	615	4	20	M 39	42	117

**KARŞILAŞTIRMA TABLOSU
COMPARISON WITH OTHER STANDARTS
EN 10210 - 1/2**

EUROPEAN STD	ITALY	GERMANY	FRANCE	GREAT BRITAIN
EN 10210-1	UNI 7806	DIN 17121 DIN 17124	NF A 35-501 NF A 49-501	BS 4360
S235JRH	Fe 360 B	St 37.2	E 24-2	
S275J0H	Fe 430 C	St 44-3 U	E 28-3	43 C
S275J2H	Fe 430 D	St 44-3 N	E 28-4	43 D
S355J0H	Fe 510 C	St 52-3 U	E 36-3	50 C
S355J2H	Fe 510 D	St 52-3 N	E 36-4	50 D
S275NH		St E 285 N		
S355NH		St E 355 N		
S460NH		St E 460 N		

COMPARISON OF EN 10210 (EU) VS. ASTM A500, A618/A 618M (USA) & CSA G40.21 (CANADA)

Standard	EN 10210	ASTM A500	ASTM A618/A 618M	CSA G40.21
Grade	S355J0H/J2H/K2H	C	II	50W
Analysis % (max)	C 0,22	C 0,23	C 0,22	C 0,23
	Mn 1,60	Mn 1,35	Mn 0,85 - 1,35	Mn 1,35
Yeld Strength Min (MPA)	355	317	345	345
Tensile Strength Min (MPA)	510	427	485	450
Elongation Min % in 2"	22	21	22	22
Impact test Min	J0H at 0°C = 27J	N.A	N.A	N.A
	J2H at -20°C = 27J	N.A	N.A	N.A
	K2H at -20°C = 40J	N.A	N.A	N.A



KİMYASAL ANALİZ % / CHEMICAL ANALYSIS %
EN 10210 - 1/2

GRADE	C Norm. W.T. mm		Si	Mn	P	S	N
	≤40	>40 ≤65					
S235JRH	≤ 0,17	≤ 0,20	-	≤ 1,40	≤ 0,040	≤ 0,040	≤ 0,009
S275J0H	≤ 0,20	≤ 0,22	-	≤ 1,50	≤ 0,035	≤ 0,035	≤ 0,009
S275J2H	≤ 0,20	≤ 0,22	-	≤ 1,50	≤ 0,030	≤ 0,030	-
S355J0H	≤ 0,22	≤ 0,22	≤ 0,55	≤ 1,60	≤ 0,035	≤ 0,035	≤ 0,009
S355J2H	≤ 0,22	≤ 0,22	≤ 0,55	≤ 1,60	≤ 0,030	≤ 0,030	-
S355K2H	≤ 0,22	≤ 0,22	≤ 0,55	≤ 1,60	≤ 0,030	≤ 0,030	-

KİMYASAL ANALİZ % / CHEMICAL ANALYSIS %

STEEL GRADE	C	Si	Mn	P	S	Nb	V	Al tot.	Ti	Cr	Ni	Mo	Cu	N
S275NH	≤ 0,20	≤ 0,40	0,50 1,40	≤ 0,035	≤ 0,030	≤ 0,050	≤ 0,08	≥ 0,020	≤ 0,03	≤ 0,30	≤ 0,30	≤ 0,10	≤ 0,35	≤ 0,015
S275NLH				≤ 0,030	≤ 0,025									
S355NH	≤ 0,20	≤ 0,50	0,90 1,65	≤ 0,035	≤ 0,030	≤ 0,050	≤ 0,12	≥ 0,020	≤ 0,03	≤ 0,30	≤ 0,50	≤ 0,10	≤ 0,35	≤ 0,020
S355NLH	≤ 0,18	-		≤ 0,030	≤ 0,025									
S420NH	≤ 0,22	≤ 0,60	1,00 1,70	≤ 0,035	≤ 0,030	≤ 0,050	≤ 0,20	≥ 0,020	≤ 0,03	≤ 0,30	≤ 0,80	≤ 0,10	≤ 0,70	≤ 0,025
S420NLH				≤ 0,030	≤ 0,025									
S460NH	≤ 0,22	≤ 0,60	1,00 1,70	≤ 0,035	≤ 0,030	≤ 0,050	≤ 0,20	≥ 0,020	≤ 0,03	≤ 0,30	≤ 0,80	≤ 0,10	≤ 0,70	≤ 0,025
S460NLH				≤ 0,030	≤ 0,025									

MEKANİK ÖZELLİKLER / MECHANICAL PROPERTIES

STEEL GRADE	Min. Yield Strength (R _{eH}) N/mm ²			Tensile Strength (R _m) N/mm ²		Elongation % Minimum				Impact Strength Minimum	
	Nominal W.T. mm			Nominal W.T. mm		Nominal W.T. mm				T°C	J
	0 ≤ 16	> 16 ≤ 40	> 40 ≤ 65	≤ 3	> 3 ≤ 65	Long. ≤ 40	Long. > 40 ≤ 65	Transv. ≤ 40	Transv. > 40 ≤ 65		
S235JRH	235	225	215	360 – 510	340 – 470	26	25	24	23	20	27
S275J0H S275J2H	275	265	255	430 – 580	410 – 560	22	21	20	19	0	27
S355J0H S355J2H S355K2	355	345	335	510 – 680	490 – 630	22	21	20	19	0	27
										-20	40

STEEL GRADE	Min. Yield Strength (R _{eH}) N/mm ²			Tensile Strength (R _m) N/mm ²	Minimum Elongation %	Minimum Impact energy KV ^a		
	at specified thickness mm			at specified thickness mm	at specified thickness ≤ 65 mm	J		
	≤ 16	> 16 ≤ 40	> 40 ≤ 65	Longitudinal ≤ 65	Longitudinal	Transverse	At test temperature of -50 °C	-20 °C
S275NH S275NLH	275	265	255	370 – 510	24	22	-	40
S355NH S355NLH	355	345	335	470 – 630	22	20	-	40
S420NH S420NLH	420	400	390	520 – 680	19	17	-	40
S460NH S460NLH	460	440	430	540 – 720	17	15	-	40
							-	40

► KAYNAK BOYUNLU FLANŞ / WELDING NECK FLANGE

- Anma Basıncı / PN:16 kgf/cm²
- DIN 2633
- EN 1092-1 TİP II

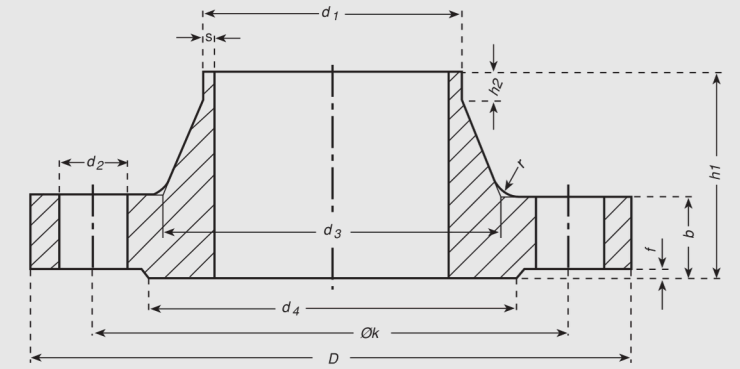

BORU / PIPE		FLANŞ / FLANGE				BOYUN NECK			ALIN ÇIKINTISI RAISED FACE		CİVATALAR BOLTS			Ağırlık Weight (7,85 kg / dm ³) kg.	
d	d ₁	D	b	k	h ₁	d ₃	s	r	h ₂	d ₄	f	Delik Hole	Vida Screw	d ₂	
10	14 17,2	90	16	60	35	25 28	1,8	4	6	40	2	4	M 12	14	0,580
15	20 21,3	95	16	65	38	30 32	2	4	6	45	2	4	M 12	14	0,648
20	25 26,9	105	18	75	40	38 40	2,3	4	6	58	2	4	M 12	14	0,952
25	30 33,7	115	18	85	40	42 45	2,6	4	6	68	2	4	M 12	14	1,14
32	38 42,4	140	18	100	42	52 56	2,6	6	6	78	2	4	M 16	18	1,69
40	44,5 48,3	150	18	110	45	60 64	2,6	6	7	88	3	4	M 16	18	1,86
50	57 60,3	165	18	125	45	72 75	2,9	6	8	102	3	4	M 16	18	2,53
65	76,1	185	18	145	45	90	2,9	6	10	122	3	4	M 16	18	3,06
80	88,9	200	20	160	50	105	3,2	8	10	138	3	8	M 16	18	3,70
100	108 114,3	220	20	180	52	125 131	3,6	8	12	158	3	8	M 16	18	4,62
125	133 139,7	250	22	210	55	150 156	4	8	12	188	3	8	M 16	18	6,30
150	159 168,3	285	22	240	55	175 184	4,5	10	12	212	3	8	M 20	22	7,75
175	191 193,7	315	24	270	60	208 210	5,4	10	12	242	3	8	M 20	22	10,0
200	216 219,1	340	24	295	62	232 235	5,9	10	16	268	3	12	M 20	22	11,0
250	267 273	405	26	355	70	285 292	6,3	12	16	320	3	12	M 24	26	15,6
300	318 323,9	460	28	410	78	338 344	7,1	12	16	378	4	12	M 24	26	22,0
350	355,6 368	520	30	470	82	390	8	12	16	438	4	16	M 24	26	28,7
400	406 419	580	32	525	85	445	8	12	16	490	4	16	M 27	30	36,3
500	508 521	715	36	650	84	548	8	12	16	610	4	20	M 30	33	59,3
600	609,6 622	840	40	770	88	652	8,8	12	18	725	5	20	M 33	36	73,4
700	711,2 720	910	40	840	104	755	8,8	12	18	795	5	24	M 33	36	75,0
800	812,8 820	1025	41	950	108	855	10	12	20	900	5	24	M 36	39	99,0
900	914,4 920	1125	48	1050	118	955	10	12	20	1000	5	28	M 36	39	119
1000	1016 1020	1255	59	1170	137	1058	10	16	22	1115	5	28	M 39	42	159



► DÜZ FLANŞ / FLAT FLANGE

- PN 40
- EN 1092-1

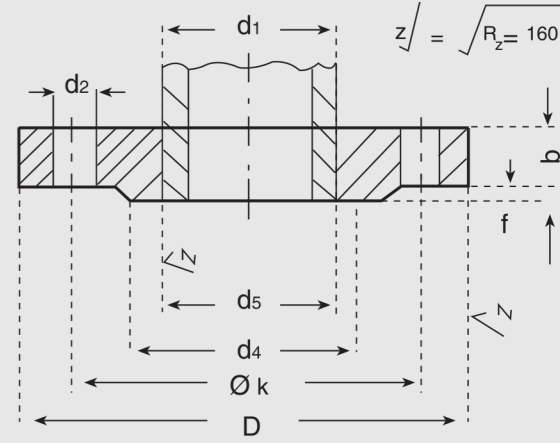

BORU / PIPE		FLANŞ / FLANGE					FATURA RAISED FACE		CIVATALAR BOLTS			Ağırlık Weight (7,85 kg / dm ³) kg.
Anma Boyutu DN	d ₁		d ₅	D	b	k	f	d ₄	Delik Hole	Vida Screw	d ₂	
	Sıra 1	Sıra 2										
15	-	20	21	95	14	65	2	45	4	M 12	14	0,60
	21,3	-	22									
20	-	25	26	105	16	75	2	58	4	M 12	14	0,90
	26,9	-	27,5									
25	-	30	31	115	16	85	2	68	4	M 12	14	1,10
	33,7	-	34,5									
32	-	38	39	140	18	100	2	78	4	M 16	18	1,70
	42,4	-	43,5									
40	-	44,5	45,5	150	18	110	3	88	4	M 16	18	1,95
	48,3	-	49,5									
50	-	57	58,1	165	20	125	3	102	4	M 16	18	2,58
	60,3	-	61,5									
65	76,1	-	77,5	185	22	145	3	122	8	M 16	18	3,30
80	88,9	-	90,5	200	24	160	3	138	8	M 16	18	4,00
100	-	108	109,6	235	26	190	3	162	8	M 20	22	5,87
	114,3	-	116									
125	-	133	134,8	270	28	220	3	188	8	M 24	26	8,10
	139,7	-	141,5									
150	-	159	161,1	300	30	250	3	218	8	M 24	26	10,05
	168,3	-	170,5									
200	219,1	-	221,5	375	36	320	3	285	12	M 27	30	17,50
250	-	267	270,2	450	42	385	3	345	12	M 30	33	28,50
	273,0	-	276,5									
300	323,9	-	327,5	515	52	450	4	410	16	M 30	33	45,58
350	355,6	-	359,5	580	58	510	4	465	16	M 33	36	62,16
	-	368	372,2									
400	406,4	-	411	660	65	585	4	535	16	M 36	39	88,05
	-	419	423,7									
450	457,0	-	462	685	SAB	610	4	560	20	M 36	39	91,76
500	508,0	-	513,5	755	SAB	670	4	615	20	M 39	42	118,16
600	610,0	-	616,5	890	SAB	795	5	735	20	M 45	48	176,16

SAB : Satın Alan Tarafından Belirlenecek.

KARBON EŞDEĞER FORMÜLÜ
CARBON EQUIVALENT VALUE (CEV)

$$CEV = C + \frac{Mn}{6} + \frac{Cr+Mo+V}{5} + \frac{Ni+Cu}{15}$$

STEEL GRADE	Maximum Carbon Equivalent (CEV) in % for specified thicknesses in mm	
	≤16	>16 ≤65
S275NH S275NLH	0,40	0,40
S355NH S355NLH	0,43	0,45
S420NH S420NLH	0,50	0,52
S460NH S460NLH	0,53	0,55

STEEL GRADE	Maximum Carbon Equivalent (CEV) in % for specified thicknesses in mm			
	≤16	>16 ≤40	>40 ≤65	>65 ≤120
S235JRH	0,37	0,39	0,41	0,44
S275J0H	0,41	0,43	0,45	0,48
S275J2H	0,41	0,43	0,45	0,48
S355J0H	0,45	0,47	0,50	0,53
S355J2H	0,45	0,47	0,50	0,53
S355K2H	0,45	0,47	0,50	0,53

Ölçüler ve Toleranslar / Dimensions and Tolerances

Outside Diameter OD ±1% with a minimum of ±0.5

Wall Thickness WT -10%



MEKANİK BORULAR / MECHANICAL PIPES EN 10297-1

KULLANIM ALANI / TYPE OF APPLICATION

GRADE	APPLICATION
E235	E235 steel for mechanical applications
E355	E355 steel for mechanical applications
E355K2	E355K2 steel for mechanical applications, with guaranteed toughness
E470, E420J2, E590K2	E470, E420J2, E590K2 steel for high yield strength mechanical applications
E730 K2	E730 K2 quenched and tempered steel with excellent tensile properties, associated with a C < 0.20%
30CrMo4	30CrMo4 quenched and tempered steel
42CrMo4	42CrMo4 quenched and tempered steel
16MnCrS5	16MnCrS5 re-sulphured casehardening steel

KİMYASAL ANALİZ % / CHEMICAL ANALYSIS %

GRADE	C	Mn	Si	P	S	Ni	V	Cr	Mo	Al tot	Nb	Ti
E235	≤0,17	≤1,20	≤0,35	≤0,030	≤0,035							
E355	≤0,22	≤1,60	≤0,55	≤0,030	≤0,035							
E355K2	≤0,20	0,90 - 1,65	≤0,50	≤0,030	≤0,030	≤0,50	≤0,12	≤0,30	≤0,10	≥0,020	≤0,050	≤0,050
E470	0,16 → 0,22	1,30 → 1,70	0,10 → 0,50	≤0,030	≤0,035		0,08 → 0,15			≥0,010	≤0,070	≤0,020
E420J2	0,16 → 0,22	1,30 → 1,70	0,10 → 0,50	≤0,030	≤0,035	≤0,40	0,08 → 0,15	≤0,30	≤0,08	≥0,010	≤0,070	≤0,050
E590K2	0,16 → 0,22	1,30 → 1,70	0,10 → 0,50	≤0,030	≤0,035	≤0,40	0,08 → 0,15	≤0,30	≤0,08	≥0,010	≤0,070	≤0,050
E730K2	≤0,20	1,40 → 1,70	≤0,50	≤0,030	≤0,030	0,30 → 0,70	≤0,12	≤0,30	0,30 → 0,45	≥0,020	≤0,050	≤0,050
30CrMo4	0,27 → 0,34	0,35 → 0,60	≤0,35	≤0,035	≤0,035			0,80 → 1,15	0,15 → 0,30			
42CrMo4	0,38 → 0,45	0,60 → 0,90	≤0,40	≤0,035	≤0,035			0,90 → 1,20	0,15 → 0,30			
16MnCrS5	0,14 → 0,19	1,0 → 1,30	≤0,40	≤0,035	0,020 → 0,040			0,80 → 1,10				

MEKANİK ÖZELLİKLER / MECHANICAL PROPERTIES

GRADE	TENSILE PROPERTIES / ÇEKME ÖZELLİKLERİ										IMPACT TEST Charpy KV long		
	Rp02 (MPa) min					Rm (MPa) min					A % long. min	T °C	J min
	Wall thickness												
≤16	>16≤40	>40≤65	>65≤80	>80≤100	≤16	>16≤40	>40≤65	>65≤100					
E235	235	225	215	205	195	360	360	360	340	25	-	-	
E355	355	345	335	315	295	490	490	490	470	22	-	-	
E355K2	355	345	335	315	295	490	490	470	470	20	-20	40	
E470	470	430	-	-	-	650	600	-	-	17	-	-	
E420J2	420	400	390	370	360	600	560	530	500	19	-20	27	
E590K2	590	540	480	455	420	700	650	570	520	16	-20	40	
E730K2	730	670	620	580	540	790	750	700	680	15	-20	40	

MEKANİK ÖZELLİKLER / MECHANICAL PROPERTIES: quenched and tempered alloy steel

GRADE	TENSILE PROPERTIES / ÇEKME ÖZELLİKLERİ										IMPACT TEST** Charpy KV long		
	Rp02 (MPa) min					Rm (MPa) min					A % long. min	T °C	J min
	Wall thickness mm												
≤8	>8≤20	>20≤50	≤8	>8≤20	>20≤50	≤8	>8≤20	>20≤50					
30CrMo4	750	630	520	950	850	750	12	13	14	20	40	45	
42CrMo4	900	750	650	1100	1000	900	10	11	12	20	30	35	

► DÜZ FLANŞ / FLAT FLANGE

- PN 16
- EN 1092-1

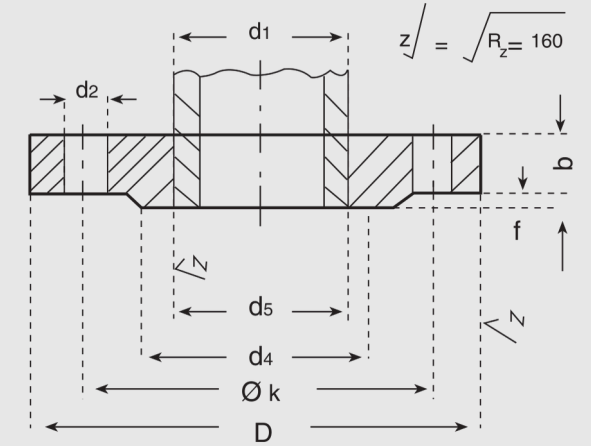

BORU / PIPE Anma Boyutu DN	d ₁		d ₅	D	b	k	FATURA RAISED FACE		CIVATALAR BOLTS			Ağırlık Weight (7,85 kg / dm ³) kg.
	Sıra 1	Sıra 2					f	d ₄	Delik Hole	Vida Screw	d ₂	
15	-	20	21	95	14	65	2	45	4	M 12	14	0,60
	21,3	-	22									
20	-	25	26	105	16	75	2	58	4	M 12	14	0,90
	26,9	-	27,5									
25	-	30	31	115	16	85	2	68	4	M 12	14	1,10
	33,7	-	34,5									
32	-	38	39	140	18	100	2	78	4	M 16	18	1,70
	42,4	-	43,5									
40	-	44,5	45,5	150	18	110	3	88	4	M 16	18	1,95
	48,3	-	49,5									
50	-	57	58,1	165	20	125	3	102	4	M 16	18	2,58
	60,3	-	61,5									
65	76,1	-	77,5	185	20	145	3	122	4	M 16	18	2,96
	88,9	-	90,5									
80	88,9	-	90,5	200	20	160	3	138	8	M 16	18	3,44
	-	108	109,6									
100	114,3	-	116	220	22	180	3	158	8	M 16	18	4,30
	-	133	134,8									
125	139,7	-	141,5	250	22	210	3	188	8	M 16	18	5,10
	-	159	161,1									
150	168,3	-	170,5	285	24	240	3	212	8	M 20	22	6,73
	219,1	-	221,5									
200	219,1	-	221,5	340	26	295	3	268	12	M 20	22	9,30
	-	267	270,2									
250	273,0	-	276,5	405	29	355	3	320	12	M 24	26	12,70
	323,9	-	327,5									
300	323,9	-	327,5	460	32	410	4	378	12	M 24	26	18,20
	355,6	-	359,5									
350	355,6	-	359,5	520	35	470	4	438	16	M 24	26	27,30
	-	368	372,2									
400	406,4	-	411	580	38	525	4	490	16	M 27	30	34,80
	-	419	423,7									
450	457,0	-	462	640	42	585	4	550	20	M 27	30	45,31
500	508,0	-	513,5	715	46	650	4	610	20	M 30	33	62,50
600	610,0	-	616,5	840	55	770	5	725	20	M 33	36	94,00
700	711	-	SAB	910	63	840	5	795	24	M 33	36	-
800	813	-	SAB	1020	74	950	5	900	24	M 36	39	-
900	914	-	SAB	1125	82	1050	5	1000	28	M 36	39	-
1000	1016	-	SAB	1255	90	1170	5	1115	28	M 39	42	-

SAB : Satın Alan Tarafından Belirlenecek.



► DÜZ FLANŞ / FLAT FLANGE

- PN 10
- EN 1092-1

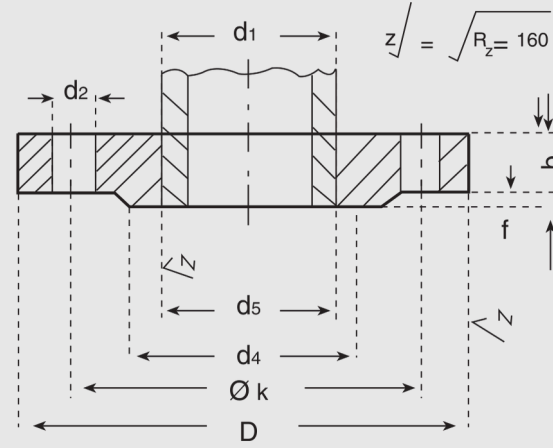

BORU / PIPE		FLANŞ / FLANGE				FATURA RAISED FACE		CIVATALAR BOLTS			Ağırlık Weight (7,85 kg / dm ³) kg.	
Anma Boyutu DN	d ₁		d ₅	D	b	k	f	d ₄	Delik Hole	Vida Screw		d ₂
	Sıra 1	Sıra 2										
15	-	20	21	95	14	65	2	45	4	M 12	14	0,60
	21,3	-	22									
20	-	25	26	105	16	75	2	58	4	M 12	14	0,90
	26,9	-	27,5									
25	-	30	31	115	16	85	2	68	4	M 12	14	1,10
	33,7	-	34,5									
32	-	38	39	140	18	100	2	78	4	M 16	18	1,70
	42,4	-	43,5									
40	-	44,5	45,5	150	18	110	3	88	4	M 16	18	1,95
	48,3	-	49,5									
50	-	57	58,1	165	20	125	3	102	4	M 16	18	2,58
	60,3	-	61,5									
65	76,1	-	77,5	185	20	145	3	122	4	M 16	18	2,96
80	88,9	-	90,5	200	20	160	3	138	8	M 16	18	3,44
100	-	108	109,6	220	22	180	3	158	8	M 16	18	4,30
	114,3	-	116									
125	-	133	134,8	250	22	210	3	188	8	M 16	18	5,10
	139,7	-	141,5									
150	-	159	161,1	285	24	240	3	212	8	M 20	22	6,73
	168,3	-	170,5									
200	219,1	-	221,5	340	24	295	3	268	8	M 20	22	8,30
	-	267	270,2									
250	273,0	-	276,5	395	26	350	3	320	12	M 20	22	11,20
	323,9	-	327,5									
300	323,9	-	327,5	445	26	400	4	370	12	M 20	22	12,80
	355,6	-	359,5									
350	-	368	372,2	505	30	460	4	430	16	M 20	22	21,05
	406,4	-	411									
400	-	419	423,7	565	32	515	4	482	16	M 24	26	26,42
	457,0	-	462									
450	457,0	-	462	615	36	565	4	532	20	M 24	26	31,92
500	508,0	-	513,5	670	38	620	4	585	20	M 24	26	38,85
600	610,0	-	616,5	780	42	725	5	685	20	M 27	30	52,74
700	711	-	SAB	895	50	800	5	800	24	M 27	30	-
800	813	-	SAB	1015	56	950	5	905	24	M 30	33	-
900	914	-	SAB	1115	62	1050	5	1005	28	M 30	33	-
1000	1016	-	SAB	1230	70	1160	5	1110	28	M 33	36	-

SAB : Satın Alan Tarafından Belirlenecek.



ALPEREN BORU EKLEME PARÇALARI
ALPEREN PIPE FITTING



► DİRSEK / ELBOW

- DIN 2605 3 D
- TS 2649/1-A
- TS EN 10253-1

Çap O.D. D mm	Duvar Kalınlığı Wall Thickness S mm	Yarıçap Radius 2xA mm	Ağırlık Theor. Weight	
			90°- Angle kg	180°- Angle kg
20	2	50 ± 5	0,04	0,08
21,3	2	55 ± 5	0,04	0,08
25	2	55 ± 5	0,05	0,10
26,9	2,3	57 ± 5	0,07	0,14
30	2,6	67 ± 5	0,09	0,18
31,8	2,6	70 ± 5	0,11	0,22
33,7	2,6	76 ± 5	0,12	0,24
38	2,6	90 ± 5	0,16	0,32
42,4	2,6	95 ± 5	0,19	0,38
44,5	2,6	102 ± 5	0,22	0,44
48,3	2,6	114 ± 6	0,27	0,54
51	2,9	127 ± 6	0,31	0,62
57	2,9	144 ± 6	0,44	0,88
60,3	2,9	152 ± 6	0,49	0,98
63,5	2,9	165 ± 6	0,57	1,14
70	2,9	184 ± 6	0,70	1,40
76,1	2,9	190 ± 6	0,79	1,58
82,5	3,2	215 ± 6	1,07	2,14
88,9	3,2	229 ± 6	1,22	2,44
101,6	3,6	267 ± 6	1,83	3,66
108	3,6	285 ± 6	2,08	4,16
114,3	3,6	305 ± 6	2,37	4,74
133	4	362 ± 6	3,64	7,28
139,7	4	381 ± 8	4,04	8,08
159	4,5	432 ± 8	5,80	11,60
168,3	4,5	457 ± 8	6,50	13,00
193,7	5,4	540 ± 8	10,60	21,20
219,1	5,9	610 ± 8	14,90	29,80
244,5	6,3	680 ± 8	19,80	39,60
267	6,3	756 ± 8	24,10	48,20
273	6,3	762 ± 10	24,90	49,80
323,9	7,1	914 ± 10	40,00	80, -
355,6	8	1067 ± 20	57,20	114,40
368	8	1067 ± 20	59,20	118,40
406,4	8,8	1219 ± 20	82,20	164,40
419	10	1219 ± 20	96,60	193,20
457,2	10	1372 ± 30	119,00	238,00
508	11	1524 ± 70	162,00	324,00
609,6	12,5	1800 ± 100	261,50	523,00
622	13	1850 ± 100	276, -	552,00
711,2	14,2	2100 ± 100	404,00	808,00
812,8	16	2400 ± 200	590,00	1180,00

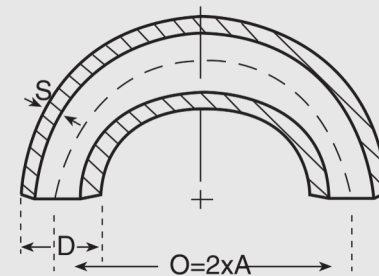
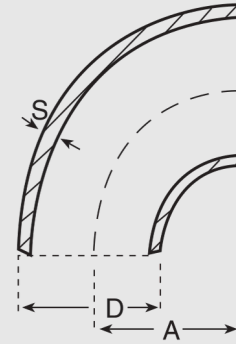

► DÜZ FLANŞ / FLAT FLANGE

- PN 6
- EN 1092-1

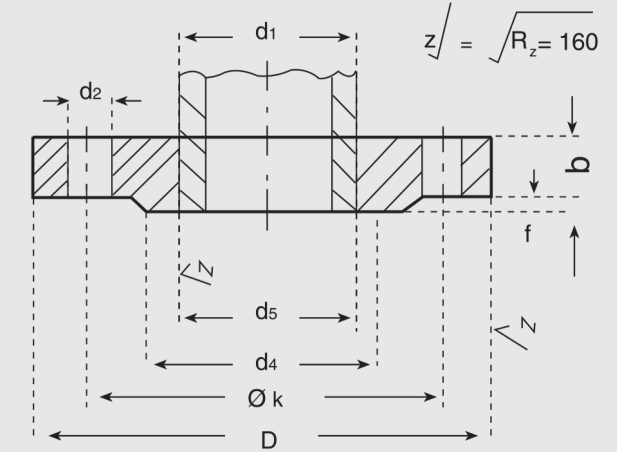
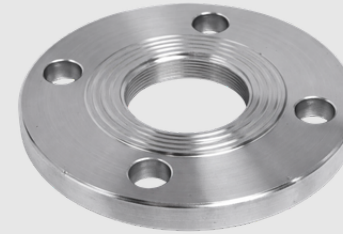

Anma Boyutu DN	BORU / PIPE		FLANŞ / FLANGE				FATURA RAISED FACE	CIVATALAR BOLTS			Ağırlık Weight (7,85 kg / dm ³) kg.	
	d ₁	d ₅	D	b	k	f	d ₄	Delik Hole	Vida Screw	d ₂		
15	-	20	21	80	12	55	2	40	4	M 10	11	0,41
	21,3	-	22									
20	-	25	26	90	14	65	2	50	4	M 10	11	0,60
	26,9	-	27,5									
25	-	30	31	100	14	75	2	60	4	M 10	11	0,74
	33,7	-	34,5									
32	-	38	39	120	16	90	2	70	4	M 12	14	1,19
	42,4	-	43,5									
40	-	44,5	45,5	130	16	100	2	80	4	M 12	14	1,39
	48,3	-	49,5									
50	-	57	58,1	140	16	110	3	90	4	M 12	14	1,53
	60,3	-	61,5									
65	76,1	-	77,5	160	16	130	3	110	4	M 12	14	1,78
80	88,9	-	90,5	190	18	150	3	128	4	M 16	18	2,86
100	-	108	109,6	210	18	170	3	148	4	M 16	18	3,02
	114,3	-	116									
125	-	133	134,8	240	20	200	3	178	8	M 16	18	4,12
	139,7	-	141,5									
150	-	159	161,1	265	20	225	3	202	8	M 16	18	4,76
	168,3	-	170,5									
200	219,1	-	221,5	320	22	280	3	258	8	M 16	18	6,65
	-	267	270,2									
250	273,0	-	276,5	375	24	335	3	312	12	M 16	18	8,80
300	323,9	-	327,5	440	24	395	4	365	12	M 20	22	11,53
	355,6	-	359,5									
350	-	368	372,2	490	26	445	4	415	12	M 20	22	15,10
	406,4	-	411									
400	-	419	423,7	540	28	495	4	465	16	M 20	22	18,40
450	457,0	-	462	595	30	550	4	520	16	M 20	22	23,78
500	508,0	-	513,5	645	30	600	4	570	20	M 20	22	26,40
600	610,0	-	616,5	755	32	705	5	670	20	M 24	26	37,10
700	711	-	SAB	860	40	810	5	775	24	M 24	26	-
800	813	-	SAB	975	44	920	5	880	24	M 27	30	-
900	914	-	SAB	1075	48	1020	5	980	24	M 27	30	-
1000	1016	-	SAB	1175	52	1120	5	1080	28	M 27	30	-

SAB : Satın Alan Tarafından Belirlenecek.



► **KEP / CAP**

- DIN 2617
- TS EN 10253-1
- TS 2649/5

ÇAP O.D. D mm	KALINLIK Wall Thickness S			Boy Length H ca. mm	Ortalama Ağırlık Approx. Weight		
	SCH 20 mm	SCH 40 mm	SCH 80 mm		SCH 20 mm	SCH 40 mm	SCH 80 mm
21,3	2	2,9	3,6	32	0,02	0,03	0,04
26,9	2,3	2,9	4	32	0,04	0,05	0,07
30	2,6	3,6	4,5	38	0,07	0,09	0,12
33,7	2,6	3,6	4,5	38	0,07	0,09	0,13
38	2,6	3,6	4,8	38	0,10	0,14	0,16
42,4	2,6	3,6	4,8	38	0,11	0,15	0,18
44,5	2,6	3,6	5,1	38	0,13	0,18	0,20
48,3	2,6	3,6	5,1	38	0,14	0,19	0,22
57	2,9	4	5,6	38	0,25	0,31	0,44
60,3	2,9	4	5,6	38	0,26	0,32	0,45
76,1	2,9	5,6	7,1	38	0,34	0,52	0,68
88,9	3,2	5,6	8	50	0,50	0,76	1,26
101,6	3,6	6,3	8,8	60	0,94	1,32	1,87
108	3,6	6,3	8,8	64	0,96	1,34	1,91
114,3	3,6	6,3	8,8	64	1,07	1,49	2,13
133	4	7,1	10	75	1,40	2,25	3,10
139,7	4	7,1	10	75	1,55	2,50	3,45
159	4,5	7,1	11	90	2,40	3,20	4,75
168,3	4,5	7,1	11	90	2,65	3,55	5,30
219,1	5,9	8	12,5	100	5,20	6,70	10,35
267	6,3	10	12,5	127	7,75	9,70	13,55
273	6,3	10	12,5	127	8,10	10,10	14,15
323,9	7,1	11	12,5	152	11,75	16,15	17,80

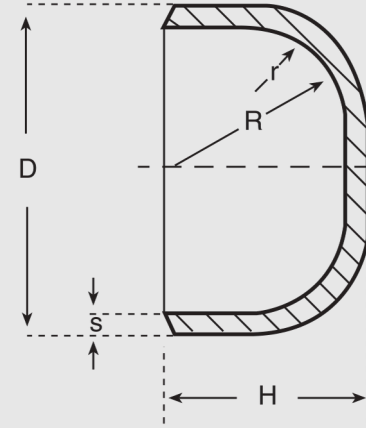

► **DİRSEK / ELBOW**

- ASME/ASTM A 234 , ANSI B16.9
- SCH40 & SCH80
- LONG RADIUS

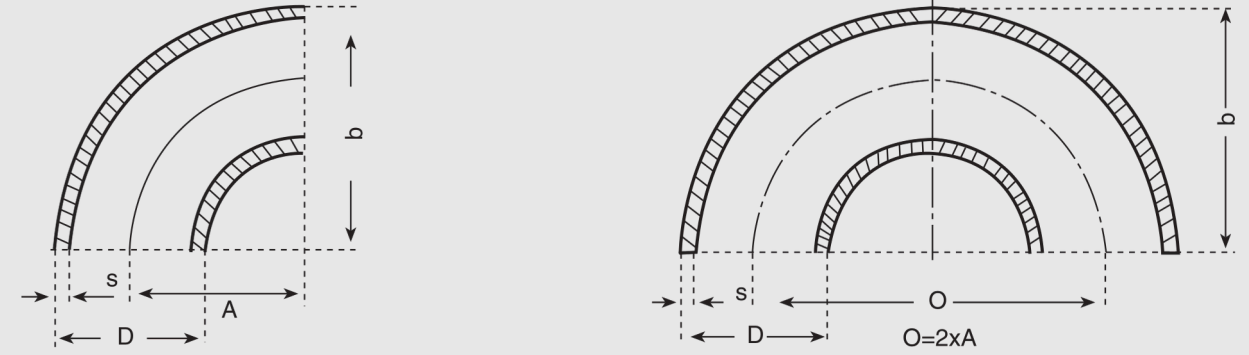

Dış Çap Outside Dia. D		Ortalama Çap. A		Yükseklik b	SCH 40		SCH 80	
					Duvar Kalınlığı Wall Thickness S mm	90° Ağırlık Theor. Weight	Duvar Kalınlığı Wall Thickness S mm	90° Ağırlık Theor. Weight
(inch)	(mm)	(mm)	Tolerans	(mm)	(mm)	Kg	(mm)	Kg
3/4"	26,9	28,5	± 2,5	42	2,9	0,077	3,9	0,100
1"	33,7	38		55	3,38	0,154	4,55	0,195
1 1/4"	42,4	47,5		69	3,56	0,263	4,85	0,340
1 1/2"	48,3	57	± 3	81	3,68	0,376	5,08	0,481
2"	60,3	76		106	3,91	0,676	5,54	0,907
2 1/2"	76,1	95		133	5,16	1,40	7,01	1,730
3"	88,9	114,5	± 4	159	5,49	2,080	7,62	2,780
4"	114,3	152,5		210	6,02	4,020	8,56	5,460
5"	139,7	190,5		260	6,67	6,770	9,53	9,100
6"	168,3	228,5	± 5	313	7,11	10,900	10,97	15,500
8"	219,1	305		415	8,18	20,900	12,7	31,000
10"	273	381		517	9,27	37,700	12,7	49,400
12"	323,9	457	± 10	619	9,53	55,800	12,7	71,200
14"	355,6	533,5		711	9,53	71,500	12,7	91,600
16"	406,4	609,5		813	9,53	93,600	12,7	120,000
18"	457,2	686	± 15	914	9,53	119,000	12,7	157,000
20"	508	762	± 35	1016	9,53	147,000	12,7	190,000

► **MANŞON / COUPLING**

- EN 10241

ANMA BOYU		Dış Çap d min.	YAPIM BOYU L min.
mm.	Parmak karşılığı		
6	R 1/8	14	17
8	R 1/4	18,5	25
10	R 3/8	21,3	26
15	R 1/2	26,4	34
20	R 3/4	31,8	36
25	R 1	39,5	43
32	R 1 1/4	48,3	48
40	R 1 1/2	54,5	48
50	R 2	66,3	56
65	R 2 1/2	82	65
80	R 3	95	71
100	R 4	122	83
125	R 5	147	92
150	R 6	174	92

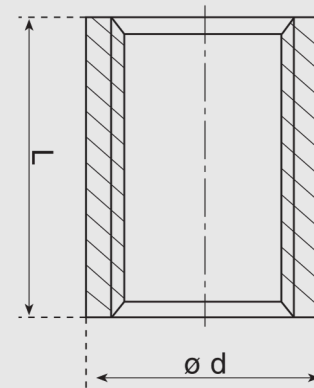



► T-FITTING / TEE

- DIN 2615
- TS 2649/6
- TS EN 10263-1

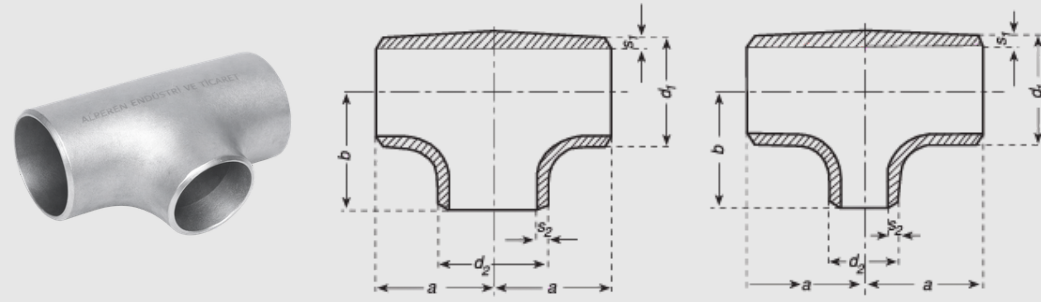

ÇAP Dia. d1	KALINLIK Wall Thickness S1			ÇAP Dia. d2	KALINLIK Wall Thickness S2			a	b
	SCH 20	SCH 40	SCH 80		SCH 20	SCH 40	SCH 80		
21,3	2	2,9		21,3	2			25	25
				17,2	1,8			25	25
				13,5	1,8	2,9		25	25
26,9	2,3	2,9		26,9	2,3			29	29
				21,3	2			29	29
				17,2	1,8	2,9		29	29
33,7	2,6	3,6		33,7	2,6			38	38
				26,9	2,3	3,6		38	38
				21,3	2	2,9		38	38
42,4	2,6	3,6		42,4	2,6			48	48
				33,7	2,6	3,6		48	48
				26,9	2,3	2,9		48	48
48,3	2,9	3,6		48,3	2,6			57	57
				42,4	2,6	3,6		57	57
				33,7	2,6	3,6		57	57
60,3	2,9	4	5,6	60,3	2,9	4		64	64
				48,3	2,6	3,6		64	60
				42,4	2,6	3,6	5,6	64	57
76,1	2,9	5,6	7,1	76,1	2,9	5,6		76	76
				60,3	2,6	4	7,1	76	70
				48,3	2,6	3,6	5,6	76	67
88,9	3,2	5,6	8	88,9	3,2	5,6		86	86
				76,1	2,9	5,6	8	86	83
				60,3	2,9	4	7,1	86	76
114,3	3,6	6,3	8,8	114,3	3,6	6,3	8,8	105	105
				88,9	3,2	5,6	8	105	98
				76,1	2,9	5,6	7,1	105	95
139,7	4,5	7,1	10	139,7	4	7,1	10	124	124
				114,3	3,6	6,3	8,8	124	117
				88,9	3,2	5,6	8	124	110
168,3	4,5	7,1	11	168,3	4,5	7,1	11	143	143
				139,7	4	7,1	10	143	137,5
				114,3	3,6	6,3	8,8	143	130
219,1	5,9	8	12,5	219,1	5,9	8	12,5	178	178
				168,3	4,5	7,1	11	178	168
				139,7	4	7,1	10	178	162
273	6,3	10	12,5	273	6,3	10	12,5	216	216
				219,1	5,9	8	12,5	216	200
				168,3	4,5	7,1	11	216	194
323,9	7,1	10	12,5	323,9	7,1	10	12,5	254	254
				273	6,3	10	12,5	254	240
				219,1	5,9	8	12,5	254	230
				168,3	4,5	7,1	11	254	220

► REDÜKSİYON / REDUCER

- DIN 2616
- TS 2649/7
- TS EN 10253-1

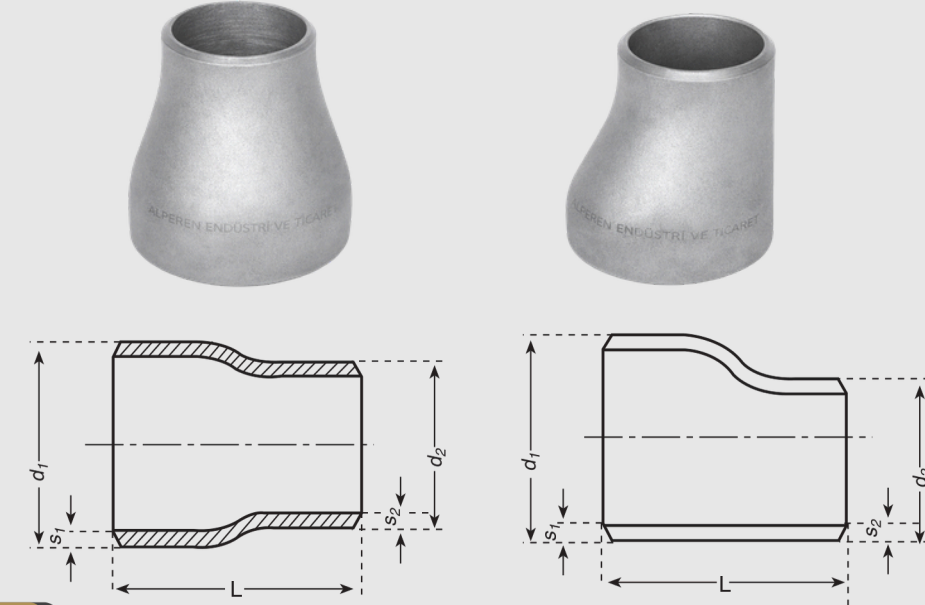

ÇAP Dia. d1	KALINLIK Wall Thickness S1			ÇAP Dia. d2	KALINLIK Wall Thickness S2			L
	SCH 20	SCH 40	SCH 80		SCH 20	SCH 40	SCH 80	
26,9	2,3	2,9		21,3	2			38
				17,2	1,8			38
33,7	2,6	3,6		26,9	2,3	2,9		50
				21,3	2	2,9		50
42,4	2,6	3,6		33,7	2,6	3,6		50
				26,9	2,3	2,9		50
				21,3	2	2,9		50
48,3	2,6	3,6		42,4	2,6	3,6		64
				33,7	2,6	3,6		64
				26,9	2,3	2,9		64
60,3	2,9	4	5,6	48,3	2,6	3,6		76
				42,4	2,6	3,6	5,6	76
				33,7	2,6	3,6		76
76,1	2,9	5,6	7,1	60,3	2,9	4		90
				48,3	2,6	3,6	5,6	90
				42,4	2,6	3,6		90
88,9	3,2	5,6	8	76,1	2,9	5,6	7,1	90
				60,3	2,9	4	7,1	90
				48,3	2,6	3,6	5,6	90
114,3	3,6	6,3	8,8	88,9	3,2	5,6	8	100
				76,1	2,9	5,6	7,1	100
				60,3	2,9	4	5,6	100
139,7	4,5	7,1	10	114,3	3,6	6,3	8,8	127
				88,9	3,2	5,6	8	127
				76,1	2,9	5,6	7,1	127
168,3	4,5	7,1	11	139,7	4	7,1	10	140
				114,3	3,6	6,3	8,8	140
				88,9	3,2	5,6	8	140
219,1	5,9	8	12,5	168,3	4,5	7,1	11	152
				139,7	4	7,1	10	152
				114,3	3,6	6,3	8,8	152
273	6,3	10	12,5	219,1	5,9	8	12,5	178
				168,3	4,5	7,1	11	178
				139,7	4	7,1	10	178
323,9	7,1	10	12,5	273	6,3	10	12,5	203
				219,1	5,9	8	12,5	203
				168,3	4,5	7,1	11	203